



Spec Sheet MWS300

Short Description

- > Warewashing cabinet machine
- > AISI 304 Stainless Steel construction
- > Multiwasher system to wash different types of tools
- > IP55 protection
- > Touch Screen Controller and emergency button switch
- > Automatic detergent dispenser

Options

- > Spinning dryer system
- > Pass-through door
- > Washing pressure inverter
- > Steam Heating
- > Rinse dosing pump
- > Automatic Tank Reload
- > Trolley elevator



TECHNICAL FEATURES

VOLTAGE/FREQUENCY

TOTAL POWER [Kw]

NET WEIGHT [Kg]

GROSS WEIGHT [Kg]

EXTERNAL MEASURES (WXDXH)[inches]

INTERNAL MEASURES (WXDXH) [inches]

ELECTRIC

400V 3F+N+T 50Hz

33.2

1240

1690

80"X58"X107"

31 1/2" X 26 3/4" X78"

STEAM

400V 3F+N+T 50Hz

12.2

1240

1690

80"X58"X107"

31 1/2" X 26 3/4" X78"

WASHING DATA

TANK [g]

52,8

52,8



Multi Products Washing

S O M E N G I L



Tender Sheet MWS300

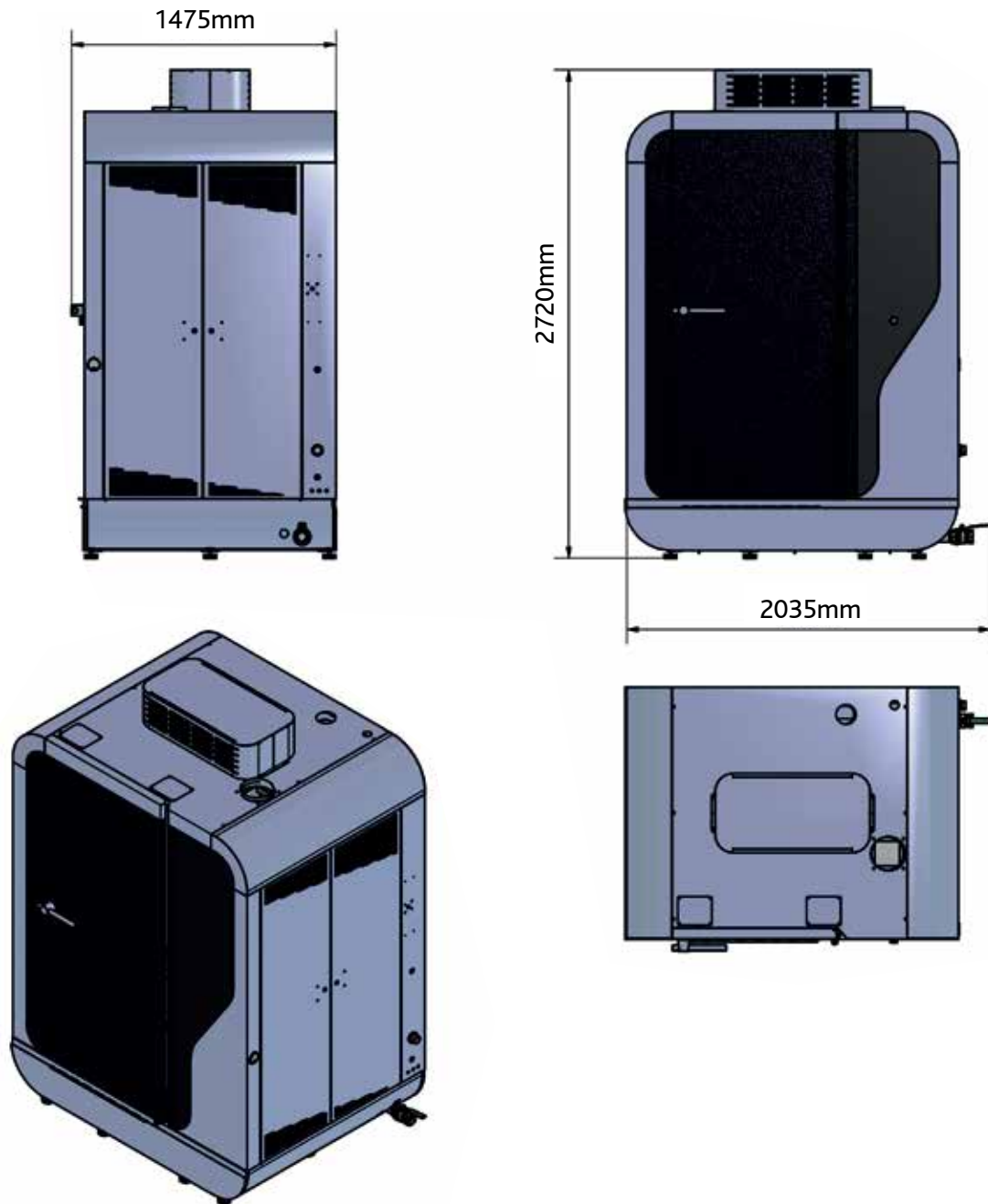



Spec Sheet MWS500

Short Description

- > Warewashing cabinet machine
- > AISI 304 Stainless Steel construction
- > Multiwasher system to wash different types of tools
- > IP55 protection
- > Touch Screen Controller and emergency button switch
- > Automatic detergent dispenser

Options

- > Spinning dryer system
- > Pass-through door
- > Washing pressure inverter
- > Steam Heating
- > Rinse dosing pump
- > Automatic Tank Reload
- > Trolley elevator



TECHNICAL FEATURES

	ELECTRIC	STEAM
VOLTAGE/FREQUENCY	400V 3F+N+T 50Hz	400V 3F+N+T 50Hz
TOTAL POWER [Kw]	37.2	16.2
NET WEIGHT [Kg]	1560	1560
GROSS WEIGHT [Kg]	1690	1690
EXTERNAL MEASURES (WXDXH)[inches]	95 1/2"X73 1/2"X107"	95 1/2"X73 1/2"X107"
INTERNAL MEASURES (WXDXH) [inches]	39 1/4" X 39 1/4" X78"	39 1/4" X 39 1/4" X78"

WASHING DATA

TANK [g]	89.8	89.8
----------	------	------



Multi Products Washing



Tender Sheet MWS500

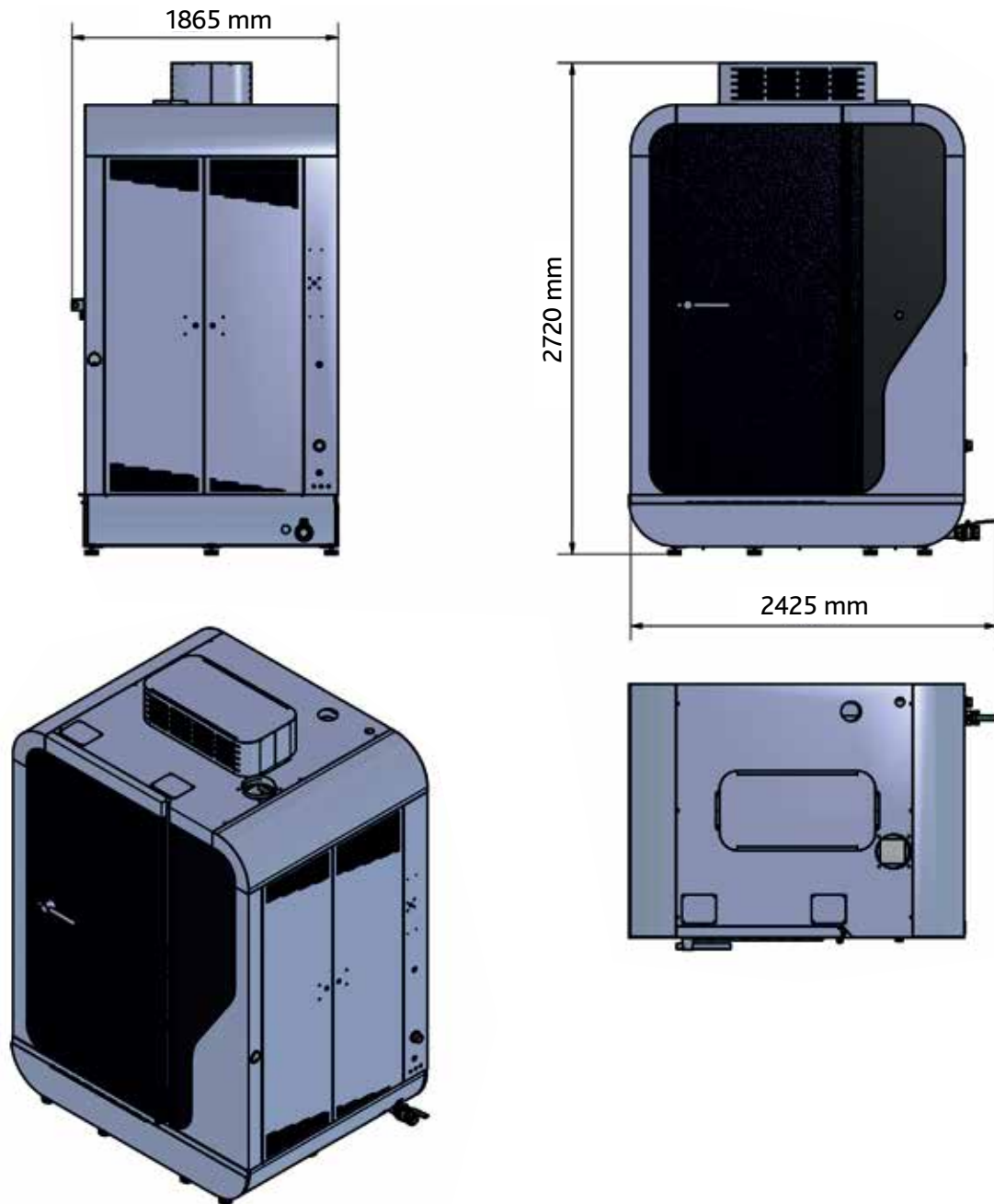



Spec Sheet MWS700

Short Description

- > Warewashing cabinet machine
- > AISI 304 Stainless Steel construction
- > Multiwasher system to wash different types of tools
- > IP55 protection
- > Touch Screen Controller and emergency button switch
- > Automatic detergent dispenser

Options

- > Spinning dryer system
- > Pass-through door
- > Washing pressure inverter
- > Steam Heating
- > Rinse dosing pump
- > Automatic Tank Reload
- > Trolley elevator



TECHNICAL FEATURES

	ELECTRIC	STEAM
VOLTAGE/FREQUENCY	208/220V or 400V 3F+N+T 50Hz	208/220V or 400V 3F+N+T 50Hz
TOTAL POWER [Kw]	47.8	16.2
NET WEIGHT [Kg]	1840	1840
GROSS WEIGHT [Kg]	2590	2590
EXTERNAL MEASURES (WXDXH)[inches]	108 1/2"X86 1/2 "X107 3/4"	108 1/2"X86 1/2 "X107 3/4"
INTERNAL MEASURES (WXDXH)[inches]	47 1/4" x 47 1/4" x 78"	47 1/4" x 47 1/4" x 78"

WASHING DATA

TANK [g]	132	132
----------	-----	-----



Multi Products Washing



Tender Sheet MWS700

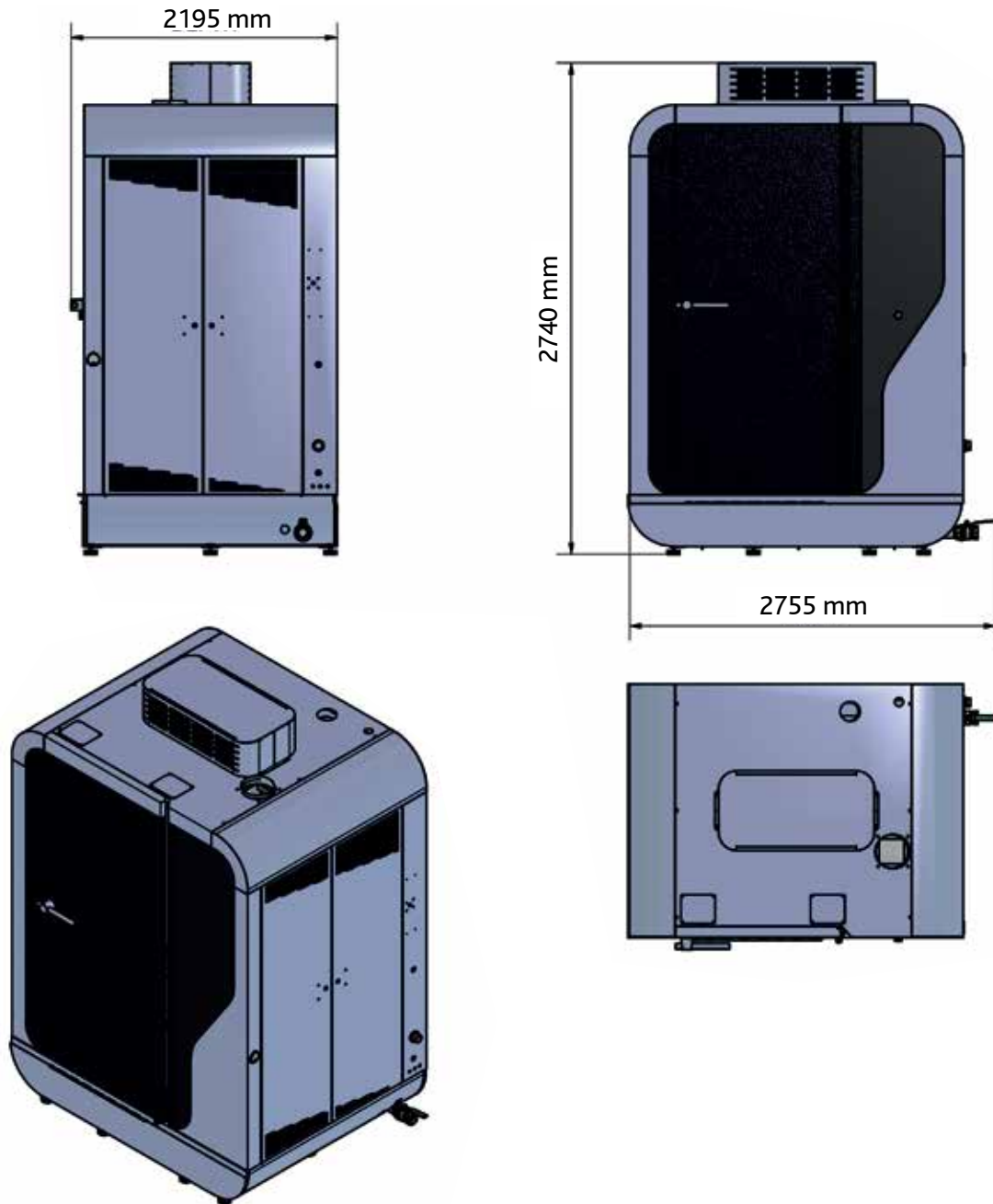



Spec Sheet MWS715

Short Description

- > Warewashing cabinet machine
- > AISI 304 Stainless Steel construction
- > Multiwasher system to wash different types of tools
- > IP65 protection (back/frontal side)
- > Touch Screen Controller and emergency button switch
- > Automatic detergent dispenser

Options

- > Spinning dryer system
- > Pass-through door
- > Washing pressure inverter
- > Steam Heating
- > Rinse dosing pump
- > Automatic Tank Reload
- > Trolley elevator



TECHNICAL FEATURES

	ELECTRIC	STEAM
VOLTAGE/FREQUENCY	400V 3F+N+T 50Hz	400V 3F+N+T 50Hz
TOTAL POWER [Kw]	47.8	16.2
TOTAL POWER (WITH INVERTER) [Kw]	68.8	16.2
NET WEIGHT [Kg]	1950	1950
GROSS WEIGHT [Kg]	2700	2700
EXTERNAL MEASURES (WXDXH)[inches]	108 1/2" x 86 1/2" x 113 3/4"	108 1/2" x 86 1/2" x 113 3/4"
INTERNAL MEASURES (WXDXH) [inches]	47 1/4" x 47 1/4" x 86 3/4"	47 1/4" x 47 1/4" x 86 3/4"

WASHING DATA

TANK [g]	132.0	132.0
----------	-------	-------



Multi Products Washing



Tender Sheet MWS715

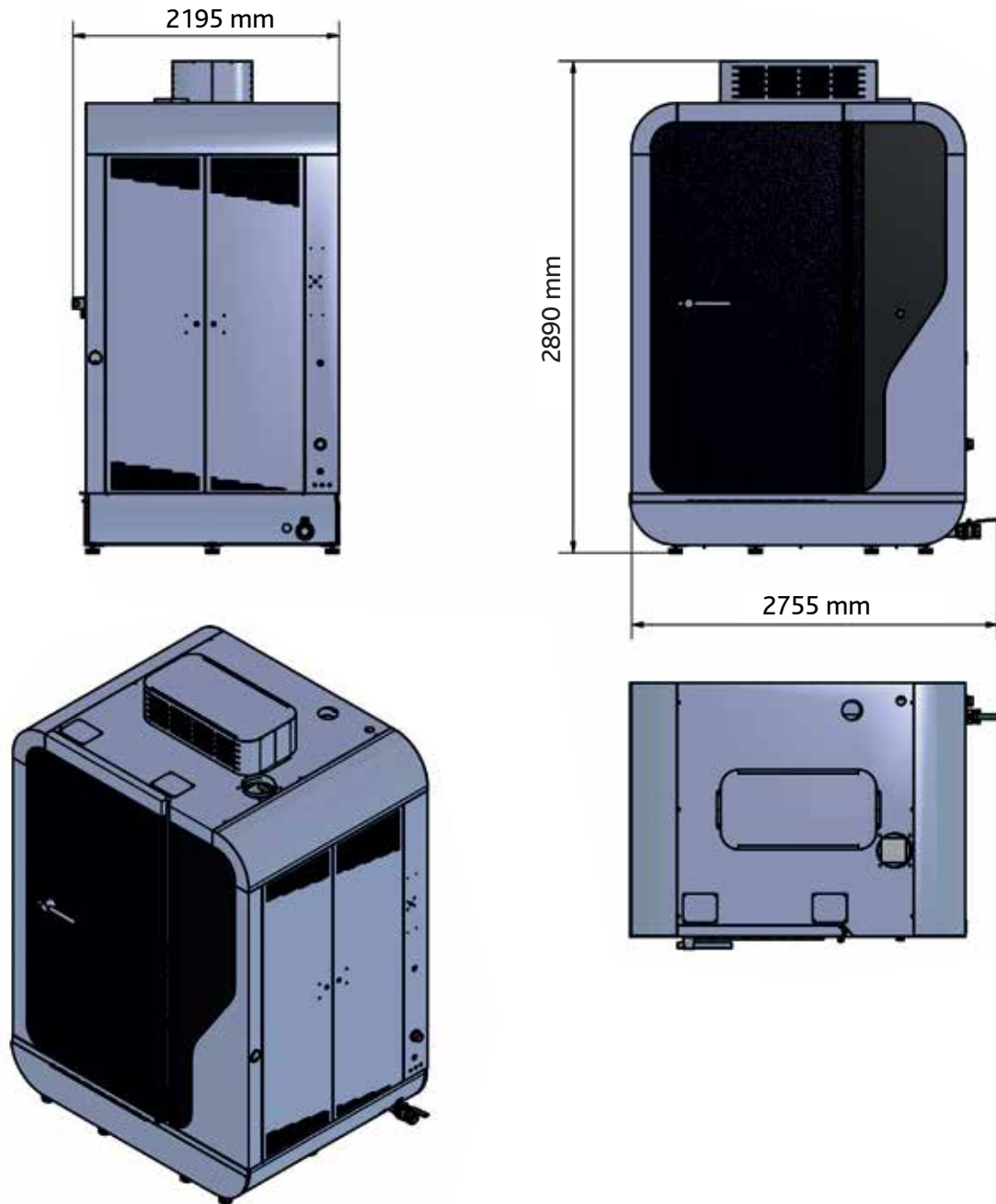

S  M E N G I L